

PSM 220 M PRATİK



MANUEL AÇILI TESTERE TEZGAHI MANUAL MITER BANDSAW MACHINE



ÖLÇÜLER DIMENSIONS

MAFSALLI MODELLER PIVOT TYPES

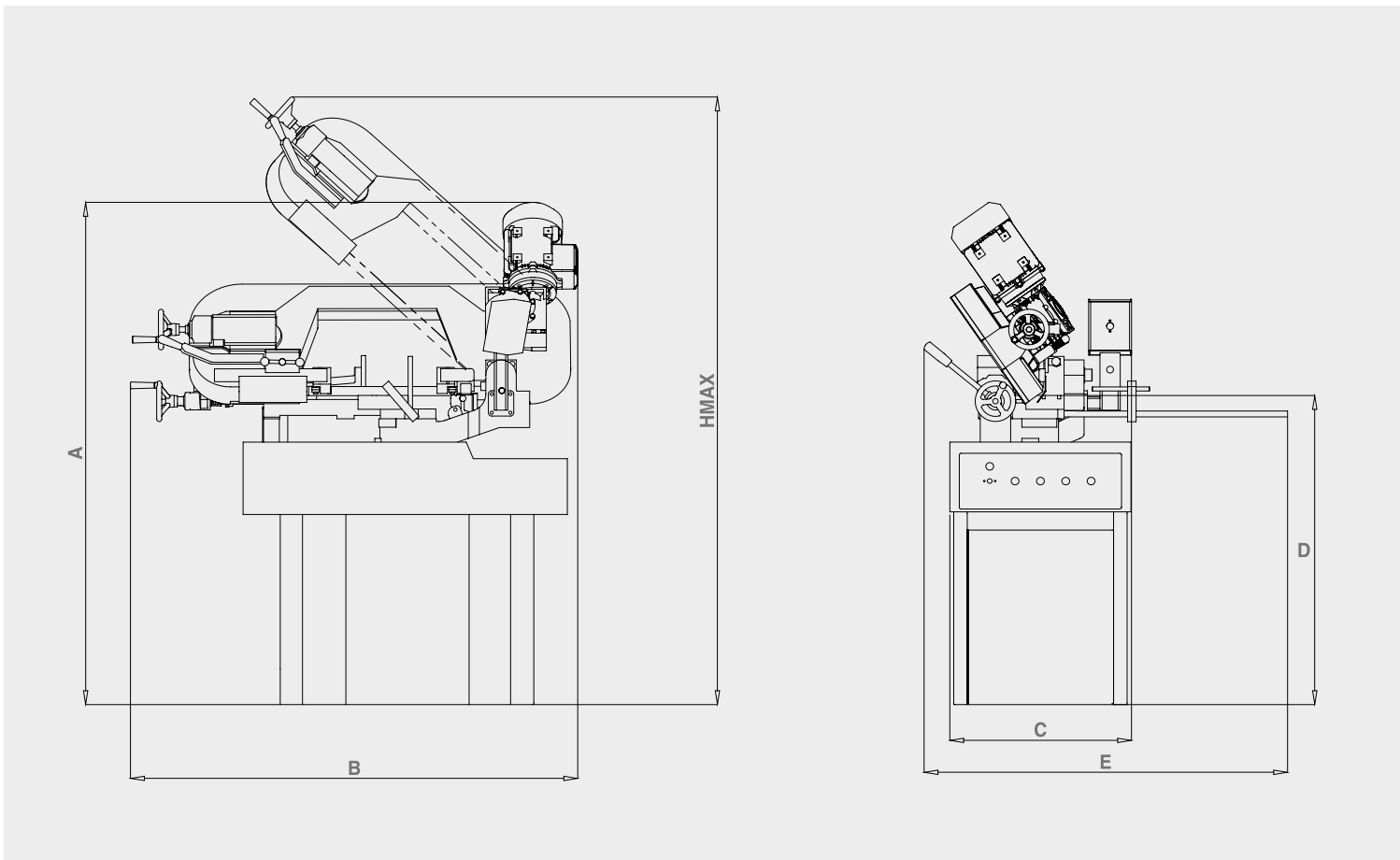

TEKNİK ÖZELLİKLER TECHNICAL FEATURES

A	1485 mm 58.46 inch	B	1323 mm 55.35 inch	C	538 mm 21.18 inch	D	915 mm 36.02 inch	E	1075 mm 42.32 inch	hmax	1800 mm 70.87 inch
---	-----------------------	---	-----------------------	---	----------------------	---	----------------------	---	-----------------------	------	-----------------------

Manuel Manual	Şerit Ölçüsü Blade Dimension 27 x 0.9 x 2500 mm 1 x 0.035 x 98.42 inch	Şerit Motoru Blade Motor 1.1 kW - 1400 d/d 1.47 hp 1400 rpm	Sürücü Motor Feeding Motor Manuel Manual
Soğutucu Motor Cooling Liquid Motor 0.12 kW 3000 d/dk 0.16 hp - 3000 rpm	Voltaj Voltage 220 V 220 V	Maksimum Güç Maximum Power 1.22 kW 1.47 hp	Kesme Hızı Cutting Speed 25 m/dk - 82 ft/min 90 m/dk - 295 ft/min
Ağırlık Weight 250 kg 551.16 lbs	Malzeme Sıkma Sistemi Material Clamping System Manuel Manual	Şerit Germe Sistemi Blade Tensioning System Hidromekanik Hydramechanic	

Kesim Kapasitesi Cutting Capacity	Kesim Kapasitesi Cutting Capacity	mm inch	60°	45°	30°	0°	15°	30°	45°	60°
220 mm 8.66 inch	250 mm 9.84 inch					220 mm 8.66 inch	200 mm 7.87 inch	150 mm 5.90 inch	80 mm 3.15 inch	
						220 x 220 mm 8.66 x 8.66 inch	180 x 180 mm 7.09 x 7.09 inch	140 x 140 mm 5.51 x 5.51 inch	80 x 80 mm 3.15 x 3.15 inch	
						170 x 250 mm 6.69 x 9.84 inch	200 x 180 mm 7.87 x 7.09 inch	140 x 150 mm 5.51 x 5.91 inch	80 x 80 mm 3.15 x 3.15 inch	