

PSM 350 M



YARI OTOMATİK AÇILI TESTERE TEZGAHI SEMI AUTOMATIC MITER BANDSAW MACHINE



ÖLÇÜLER DIMENSIONS

MAFSALLI MODELLER PIVOT TYPES

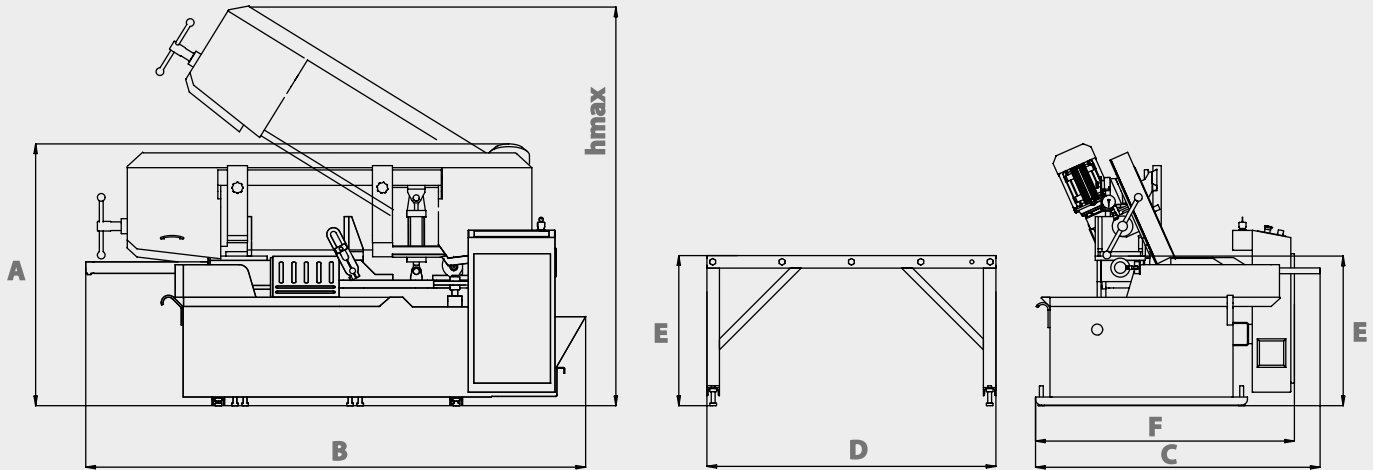

TEKNİK ÖZELLİKLER TECHNICAL FEATURES

A	1360 mm 53.54 inch	B	2600 mm 102.36 inch	C	1480 mm 58.27 inch	D	1500 mm 59.06 inch	E	780 mm 30.71 inch	F	1355 mm 53.35 inch	hmax	2080 mm 81.89 inch
---	-----------------------	---	------------------------	---	-----------------------	---	-----------------------	---	----------------------	---	-----------------------	------	-----------------------

Yarı Otomatik Semi Automatic	Seri Ölçüsü Blade Dimension 34 x 1.1 x 4570 mm 1 1/4 x 0.042 x 180 inch	Seri Motoru Blade Motor 4 kW - 1500d/dk 5.36 hp - 1500 rpm	Sürücü Motor Feeding Motor Manuel Manual
Hidrolik Motor Hydraulic Pump Motor 0.75 kW - 1400 d/dk 1 hp - 1400 rpm	Soğutucu Motor Cooling Liquid Motor 0.12 kW - 3000d/dk 0.16 hp - 3000 rpm	Voltaj Voltage 400 V 400 V	Maksimum Güç Maximum Power 4.87 kW 6.5 hp
Kesme Hızı Cutting Speed 15 m/dk - 49 ft/min 100 m/dk - 328 ft/min	Ağırlık Weight 1140 kg 2513 lbs	Malzeme Sıkma Sistemi Material Clamping System Hidrolik Hydraulic	Şerit Germe Sistemi Blade Tensioning System Hidromekanik Hydramechanic

90°	60°	45°	30°	0°	70°	45°	60°
Kesim Kapasitesi Cutting Capacity	Kesim Kapasitesi Cutting Capacity						
350 mm 13.78 inch	460 mm 18.11 inch				350 mm 13.78 inch	350 mm 13.78 inch	300 mm 11.81 inch
					350 x 350 mm 13.78 x 13.78 inch	350 x 350 mm 13.78 x 13.78 inch	250 x 250 mm 9.84 x 9.84 inch
					350 x 460 mm 13.78 x 18.11 inch	300 x 350 mm 11.81 x 13.78 inch	250 x 300 mm 9.84 x 11.81 inch