

PSM 420 / 600 M



YARI OTOMATİK AÇILI TESTERE TEZGAHI SEMI AUTOMATIC MITER BANDSAW MACHINE



ÖLÇÜLER DIMENSIONS

MAFSALLI MODELLER PIVOT TYPES

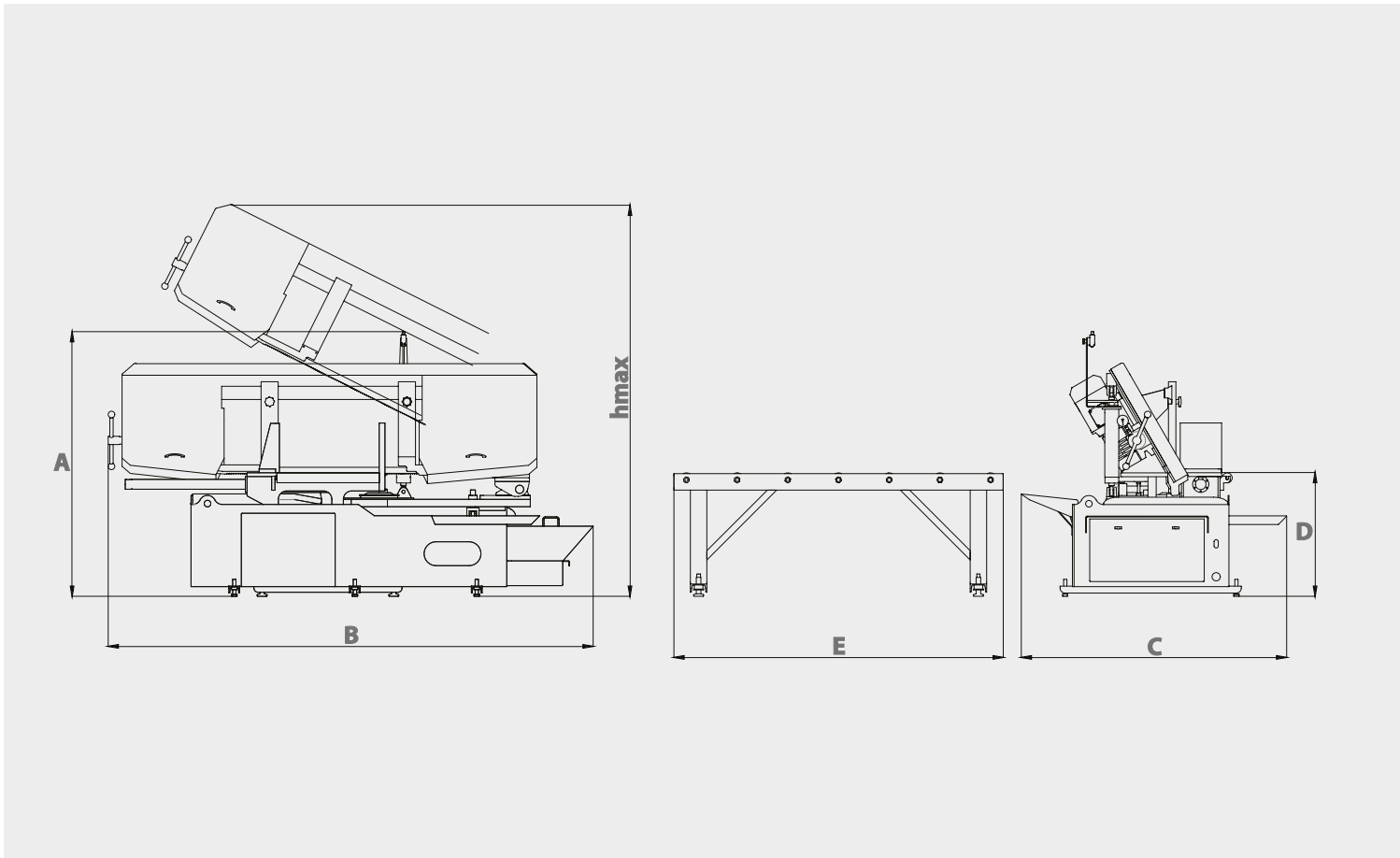

TEKNİK ÖZELLİKLER TECHNICAL FEATURES

| | | | | | | | | | | | |
|---|-----------------------|---|------------------------|---|-----------------------|---|----------------------|---|-----------------------|------|-----------------------|
| A | 1610 mm 63.39 inch | B | 2920 mm 114.96 inch | C | 1615 mm 63.58 inch | D | 750 mm 29.53 inch | E | 2000 mm 78.74 inch | hmax | 2380 mm 93.70 inch |
|---|-----------------------|---|------------------------|---|-----------------------|---|----------------------|---|-----------------------|------|-----------------------|

| | | | | | | | |
|--|--|--|---|--|--|--|---|
| | Yarı Otomatik Semi Automatic | | Şerit Ölçüsü Blade Dimension 41 x 1.3 x 5280 mm 1 1/2 x 0.050 x 207.8 inch | | Şerit Motoru Blade Motor 4 kW - 1500d/dk 5.36 hp - 1500 rpm | | Sürücü Motor Feeding Motor Manuel Manual |
| | Hidrolik Motor Hydraulic Pump Motor 0.75 kW - 1400 d/dk 1 hp - 1400 rpm | | Soğutucu Motor Cooling Liquid Motor 0.12 kW - 3000d/dk 0.16 hp - 3000 rpm | | Voltaj Voltage 400 V 400 V | | Maksimum Güç Maximum Power 4.87 kW 6.53 hp |
| | Kesme Hızı Cutting Speed 15 m/dk - 49 ft/min 100 m/dk - 328 ft/min | | Ağırlık Weight 1454 kg 3205 lbs | | Malzeme Sıkma Sistemi Material Clamping System Hidrolik Hydraulic | | Şerit Germe Sistemi Blade Tensioning System Hidromekanik Hydramechanic |

| | | | | | | | | |
|--------------------------------------|--------------------------------------|------------|------------------------------------|------------------------------------|------------------------------------|------------------------------------|------------------------------------|------------------------------------|
| | 90° | | | | | | | |
| Kesim Kapasitesi Cutting Capacity | Kesim Kapasitesi Cutting Capacity | mm inch | 330 mm 12.99 inch | 420 mm 16.54 inch | 420 mm 16.54 inch | 420 mm 16.54 inch | 420 mm 16.54 inch | 420 mm 16.54 inch |
| 420 mm 16.54 inch | 600 mm 23.62 inch | ● | 270 x 270 mm 10.63 x 10.63 inch | 420 x 420 mm 16.54 x 16.54 inch | 420 x 420 mm 16.54 x 16.54 inch | 420 x 420 mm 16.54 x 16.54 inch | 420 x 420 mm 16.54 x 16.54 inch | 420 x 420 mm 16.54 x 16.54 inch |
| | | ■ | 190 x 310 mm 7.48 x 12.20 inch | 250 x 500 mm 9.84 x 19.69 inch | 420 x 600 mm 16.54 x 23.62 inch | 420 x 600 mm 16.54 x 23.62 inch | 420 x 600 mm 16.54 x 23.62 inch | 420 x 600 mm 16.54 x 23.62 inch |